

Régulateur 5V

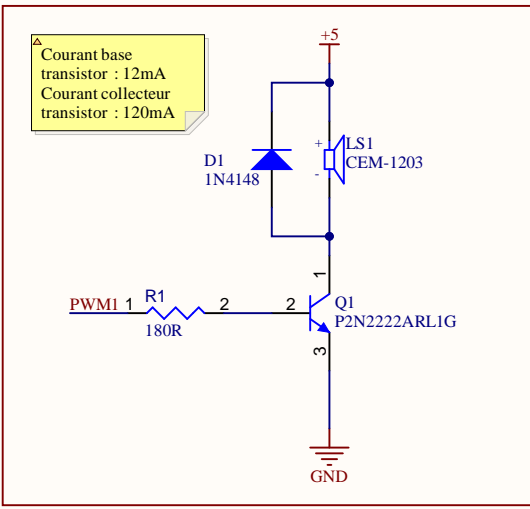

Buzzer

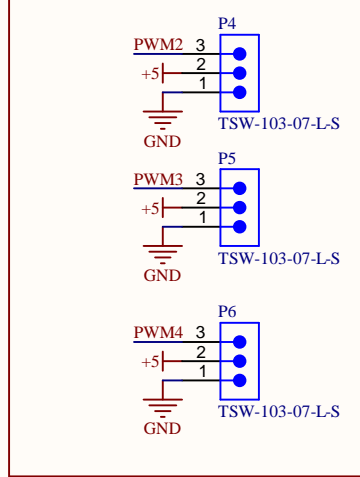

Pin Header Servo Motor

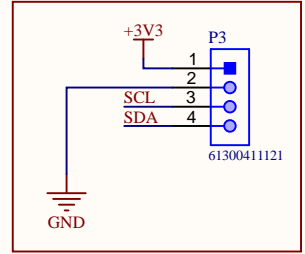

Pin Header I2C

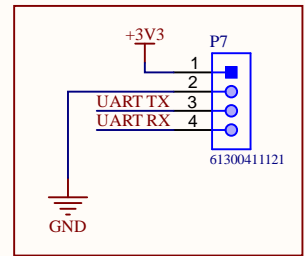

Pin Header UART

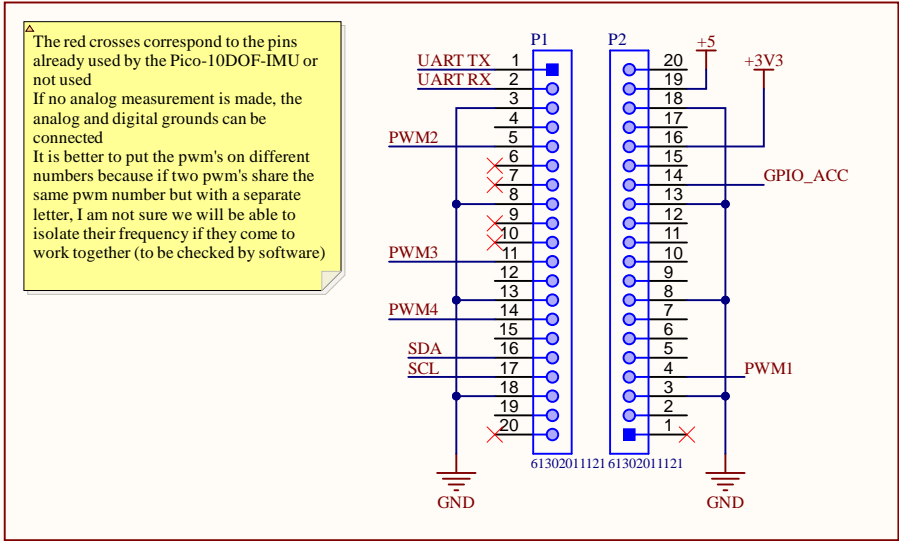

Raspberry pico Connector

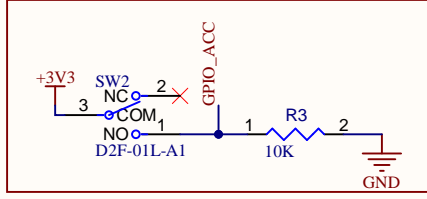

Accelerator contact

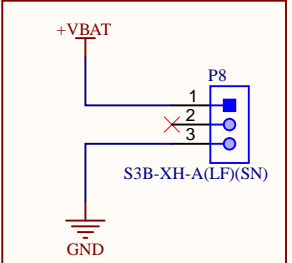

Connector JST

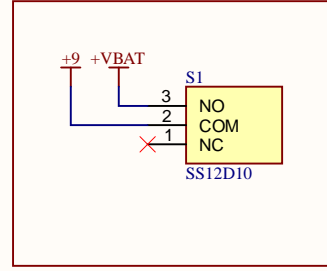

Interrupteur alimentation

Title Raspberry pico holder for rocketery		
Size A4	Number	Revision V1.4
Date: 9/19/2023	Sheet of	
File: C:\Users\l...ChildPCBRocketV4.SchDoc	Drawn By: Paul Mialthe	

